



Key Issues for Renewable Heat in Europe (K4RES-H)

Contract EIE/04/204/S07.38607

Version July 2006 – Interim report

Deliverable 7 : Overview of existing technologies for the measurement of the energy delivery for geothermal systems, including accuracy of measurement and typical costs

Objectives

This report gives a survey of the state of the art of measuring heat delivery in larger systems, looking also at the costs and accuracy of the measuring systems.

Definitions

Firstly, we define the concept of geothermal energy in order to present an harmonized view of the measurement presented :

Geothermal Energy is the energy in form of heat beneath the surface of the solid earth.

Within the EU member states, this definition is not yet used universally. It is accepted in most of Central and Northern Europe, however, in some countries differing national opinions want to limit geothermal energy to resources above a certain temperature level. There are many ways to bring geothermal heat to good use, either direct or through heat pumps, the latter allowing for adjusting the delivery temperature level to the needs of the user. We mainly can distinguish two areas:

- **Direct Use** – Geothermal heat is produced at higher temperature levels (above ca. 25 °C), suitable for direct heating. This typically means deeper drillings (>200 m, sometimes several km) and large installations. In some cases heat pumps are installed also in this kind of applications, in order to bring the delivery temperature to desired values.
- **Geothermal Heat Pumps** (Ground Source Heat Pumps, GSHP) – Geothermal heat is produced at low temperature levels, so a heat pump is required to increase the temperature to useful levels. Depth is typically less than ca. 200 m, the size of plants can range from small residential houses to large offices, etc.; cooling often is combined into these type of applications.

To define the RES- HEAT production, in this project K4RES-H, we address the total amount of produced renewable and useful heat (net heat production).

This definition comprises the following specifications:

- The heat is measured directly after the conversion what means that all storage and transfer issues are neglected.
- Auxiliary energy supply within the conversion process is only considered when being a considerable amount of more than 5 % (i.e.in the case of heat pumps).
- K4RES-H recognizes heat which is produced for sale as well as for the own consumption. Consequently, the IEA differentiation between “public producer” and “autoproducer” is neglected.
- In cogeneration only the total amount of useful heat demand is considered as it is defined in the EC Cogeneration Directive

The figures below explain these assessments:

Figure 1 :

Measurement of geothermal heat pump systems; for geothermal district heating, geothermal heat is measured at the heat exchangers from the thermal water circuit to the system, not taking into account the peak boilers, heat pumps etc. in the district heating supply system

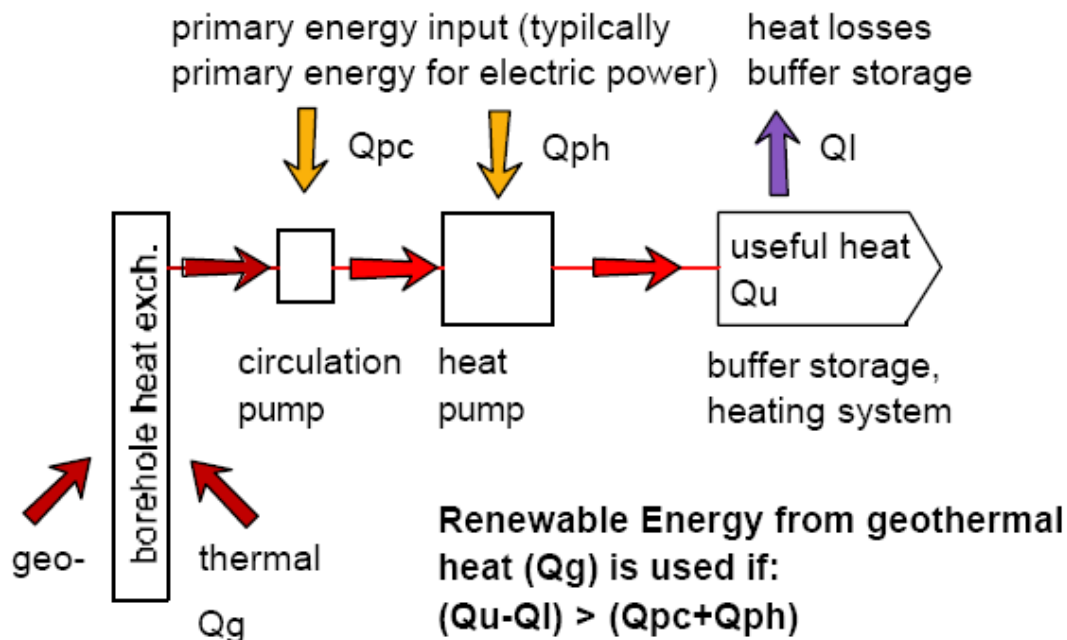
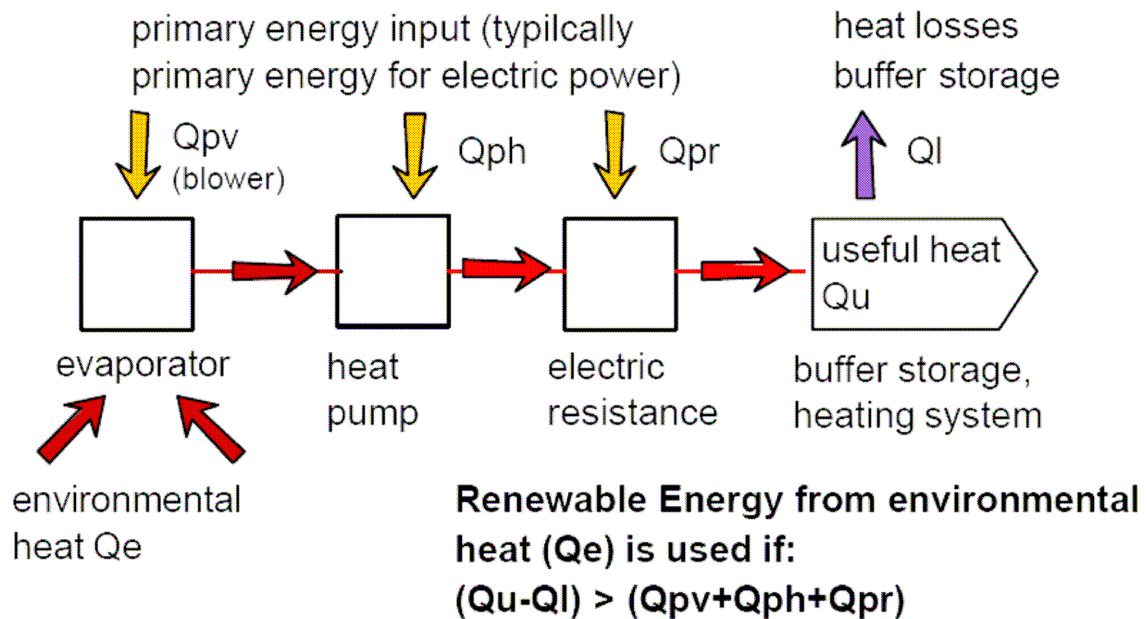

Figure 2 :



Distinction of suitable subsectors

Geothermal energy has to define specific subsectors which are suitable for individual measurement and calculation methodologies.

For geothermal energy, sub-sectors are :

- geothermal district heating
- large commercial buildings with geothermal heat pump heating and cooling
- multi-family houses
- single-family, residential buildings

Basic Principles of Heat Measurement

A general overview about heat measurement for Geothermal energy.

The monitoring strategy for GHPs can be classified into:

Basic Parameters:

- Heat pump demand (kW) and energy (kWh),
- Supply and return ground-loop temperatures, and
- Flow in ground loop, a one-time measurement.

Comprehensive Parameters:

- Ground-loop pump kW and kWh, and
- Space and outside temperatures.

Principle

The measurement of a flow of thermal energy is based on the measurement of two physical properties, e.g. a flow and a temperature difference. The analogy with the measurement of electrical energy is illustrated in the figures below.

The electrical energy [Wh] consumed in the resistance is calculated from the potential difference [V] measured between point A and B, and the flow of electrons, current [A]

The equivalent to consumed thermal energy is calculated from the temperature difference between point C and D [degree C] and the flow of water [m³/s].

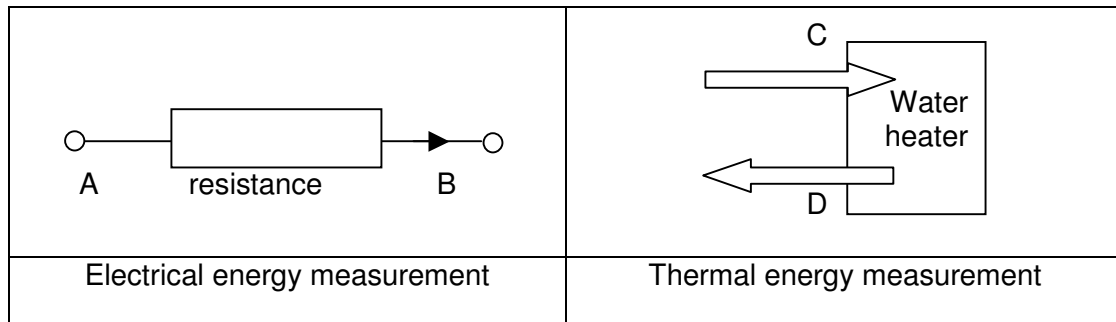

The measurement of thermal energy is in principle similar to electrical energy, however due to the physical differences, like dimension of water pipes, complexity of installations it is in practice more difficult than electrical energy measurement. The accuracy of the measurements depends not only on the sensors and instruments used but also on the correct place where the sensors are positioned.

There are different types of parameters which have to be measured for calculating the quantity of heat produced:

- o the flow F [m³/s]
- o the temperature:
 - the in temperature t_{in} [K]
 - the out temperature t_{out} [K]
- o the time t [s]

Those parameters allow calculating the heat power P [kW]:

$$P = \rho * C_p * V * (t_{in} - t_{out})$$

With :

- ρ : the volumetric mass [kg/m³]
- C_p : the mass heat capacity [J/(kg*K)]

The mass heat capacity depends of the pressure, the temperature and the nature of the fluid used. For example, if the water contents glycol in a certain percentage, it is necessary to adapt the C_p . If the pressure varies, it is also necessary to measure the pressure.

The following definitions are required:

Mass heat capacity: quantity of energy, bring by heat exchange, for increasing the temperature of one unit of mass by one degree. [GIECK, 1997]

With the power, it is possible to calculate the quantity of heat energy Q [kJ]:

$$Q = P * t^1$$

¹ Source: BERA F., 2006

Main measurement parameters

Heat counters, from the smallest domestic appliances to the largest industrial equipment with far more than 10 MWatt ratings, consist of three basic parts:

1. Flow meter (water is used almost exclusively as heat transfer medium)
2. Temperature sensors (usually two parts to measure a temperature difference)
3. Processor (often also called integrator)

Technological specifications for all three parts are given in the following.

Flow meters

Various principles to measure the flow are under use. The most prominent flowmeters are:

- electromagnetic flowmeter (used for conductive liquid: water, water with glycol)
- coreolis mass flowmeter
- ultrasonic flowmeter
- vortex flowmeter
- flowmeter with irradiation impeller

Principle of electromagnetic flowmeter²

Faraday's law of induction states that a conductor moving in a magnetic field induces an electrical voltage. With a magmeter, the flowing fluid is the moving conductor.

The constant-strength magnetic field is generated by two field coils, one on either side of the measuring tube. Two measuring electrodes on the inside wall of the tube are at right angles to the coils and detect the voltage induced by the fluid flowing through the magnetic field. The induced voltage is proportional to flow velocity and thus to volume flow.

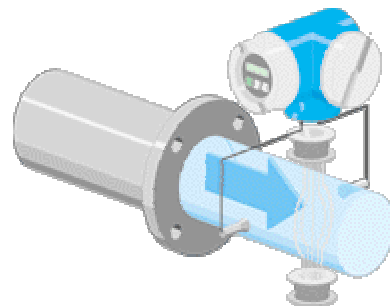

The magnetic field is generated by a pulsed direct current with alternating polarity. This ensures a stable zero point, and makes the measurement insensitive to influences from multi-phase or inhomogeneous liquids or low conductivity.

Advantages of electromagnetic flowmeter

- The principle is virtually independent of pressure, density, temperature and viscosity
- Even fluids with entrained solids can be metered (e.g. ore slurry, cellulose pulp)
- Large nominal-diameter range available (DN 2...2000)
- Free pipe cross-section (CIP/SIP cleaning, piggable)
- No moving parts
- Minimum outlay for maintenance and upkeep
- No pressure losses
- Very high turndown up to 1000:1
- High degree of measuring dependability and reproducibility, good long-term stability

Swimming against the flow requires more power and more time than swimming with the flow.

Ultrasonic flow measurement is based on this elementary transit time difference effect. Two sensors mounted on the pipe simultaneously send and receive ultrasonic pulses.

² www.endress.com, April 2006

At zero flow, both sensors receive the transmitted ultrasonic wave at the same time, i.e. without transit time delay. When the fluid is in motion, however, the waves of ultrasonic sound do not reach the two sensors at the same time.

This measured "transit time difference" is directly proportional to the flow velocity and therefore to flow volume.

Advantages of ultrasonic flowmeter

- Non-contact measurement from outside. Ideal for measuring highly aggressive liquids or fluids under high pressure
- With homogeneous fluids, the principle is independent of pressure, temperature, conductivity and viscosity
- Usable for a wide range of nominal diameters (DN 15...4000)
- Direct meter installation on existing pipes. Retrofitting is also possible
- Commissioning without process interruption
- Non-invasive measurement
- No pipe constrictions, no pressure losses
- No moving parts. Minimum outlay for maintenance and upkeep
- High life expectancy (no abrasion or corrosion by the fluid)

Doppler ultrasonic flowmeters operate on the Doppler shift principal, whereby the transmitted frequency is altered linearly by being reflected from particles and bubbles in the fluid. The net result is a frequency shift between transmitter and receiver frequencies that can be directly related to the flow velocity. If the pipe internal diameter is known, the volumetric flow rate can be calculated.

Doppler meters require a minimum amount of solid particles or air in the line to achieve measurements. Within the Time Meter Measurement Principle are made by sending bursts of signals through a pipe. The measurement of flow is based on the principle that sound waves travelling in the direction of flow of the fluid require less time than when travelling in the opposite direction.

At zero velocity, the transit time or ΔT is zero. If we know the diameter of the pipe, the pipe wall thickness and the pipe wall material the angle of refraction can be calculated automatically and we will know how far apart to space our transducers. The difference in transit times of the ultrasonic signals is an indication for the flow rate of the fluid.

Since ultrasonic signals can also penetrate solid materials, the transducers can be mounted onto the outside of the pipe. Fast Digital Signal Processors and signal analysis guarantee reliable measuring results even under difficult conditions where previously ultrasonic flowmeters have failed.

Thermal Mass Flow Meters are based on an operational principle that states that the rate of heat absorbed by a flow stream is directly proportional to its mass flow. As molecules of a moving gas/liquid come into contact with a heat source, they absorb heat and thereby cool the source.

At increased flow rates, more molecules come into contact with the heat source, absorbing even more heat.

The amount of heat dissipated from the heat source in this manner is proportional to the number of molecules of a particular gas/liquid (its mass), the thermal characteristics of the gas/liquid, and its flow characteristics.

Principle of vortex flowmeter³

This measuring principle is based on the fact that vortices are formed downstream of an obstacle in a fluid flow, e.g. behind a bridge pillar. This phenomenon is commonly known as the Kármán vortex street. When the fluid flows past a bluff body in the measuring tube, vortices are alternately formed on each side of this body. The frequency of vortex shedding down each side of the bluff body is directly proportional to mean flow velocity and therefore to volume flow. As they shed in the downstream flow, each of the alternating vortices creates a local low pressure area in the measuring tube. This is detected by a capacitive sensor and fed to the electronic processor as a primary, digitized, linear signal.

The measuring signal is not subject to drift. Consequently, vortex meters can operate an entire life long without recalibration.

Capacitive sensors with integrated temperature measurement can directly register the mass flow of saturated steam as well, for example.

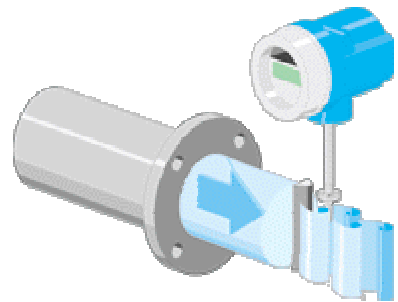

Advantages of vortex flowmeter

- Universally suitable for measuring liquids, gases and steam
- Largely unaffected by changes in pressure, temperature and viscosity
- High long-term stability (lifetime K factor), no zero-point drift
- No moving parts
- Marginal pressure loss
- Easy to install and commission
- Large turndown of typically 10:1 to 30:1 for gas/steam or 40:1 for liquids
- Large temperature range from -200...+400 °C

Flowmeter with irradiation impeller⁴

It is a measuring instrument which determines the flow with the rotation velocity of the impeller. After flow of a specific volume, the flowmeter sends an impulse to the calorimeter.



Figure 2 Flowmeter with irradiation impeller

Temperature sensors

Sensors and instruments are available on the market that perform the same measurement but vary significantly in accuracy and precision. To measure temperatures in a flow of water, usually thermocouples or platinum resistance (PT-) sensors are used. Thermocouple sensors are available for different temperature ranges each with its own accuracy. A PT100 temperature sensor can have a higher precision than a thermocouple. Note that the quality of the instruments and sensors are not related to the measurement itself. A PT100 temperature sensor can be measured in different ways (2-, 3- or 4-wires) with different accuracies.

³ www.endress.com, April 2006

⁴ www.resol.de, April 2006

2 types of temperature sensor can be used in this application:

- the resistance temperature detector
- the thermocouple thermometer

Resistance temperature detector [www.endress.com, April 2006]

A Resistance Temperature Detector (RTD) is a temperature responsive device based on a predictable resistance change in the sensing element. The EN 60751 standard specifies requirements for industrial Platinum resistance sensors and covers the Pt 100 thermometers.

The Pt 100 sensing element has a resistance of $100\ \Omega$ at 0°C .

According to EN standard and most common industrial applications, the Pt 100 type sensors are used for temperature measurement and control in the range from -50°C to 400°C or -200°C to 600°C .

RTDs offer three main advantages:

- high accuracy
- excellent long-term stability
- high signal output level which allows transmission over long distances without ancillary equipment.

Basic construction of Platinum resistance elements cannot be used directly in contact with process environments, hence the complete thermometers are built as assemblies which can withstand light, medium and heavy duty industrial conditions.

In general, the sensor assembly includes three components:

- the resistance thermometer inset
- the protecting tube (thermowell)
- the terminal housing.

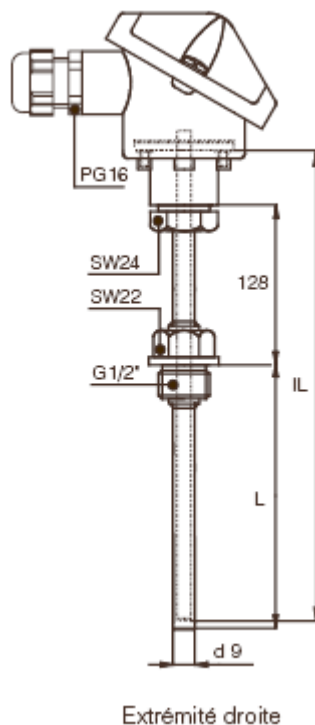

Figure 3 Resistance temperature detector RTD PT 100

Thermocouple thermometer⁵

A thermocouple (TC) consists of two wires of different conductive material, connected each other by means of two junctions forming an electrical circuit. If one junction is at temperature T1 and the other at T2, then an electromotive force is generated in the circuit, and it depends on the materials and temperatures T1 and T2 (Seebeck effect). In an industrial TC thermometer one junction is the measuring joint, and the other is a reference one which is usually located in correspondence of the conversion electronics (transmitter).

According to EN/ANSI standards and most common industrial applications, the thermocouple sensors are used for temperature measurement and control in the range from -40°C to 1800°C.

Thermocouples offer three main advantages: Good accuracy, excellent response time and wide measuring range.

Basic construction of thermocouple sensing elements cannot be used directly in contact with process environments, hence the complete thermometers are built as assemblies which can withstand light, medium and heavy duty industrial conditions.

In general, the sensor assembly includes three components:

- the thermocouple inset
- the protecting tube (thermowell)
- the terminal housing

Calculator

With the sensors shown in point 2, the parameters are measured. It is now necessary to calculate the calorific power and the calorific energy with a calculator.

Heat Measurement in renewable Technologies : Specifications for Geothermal

For geothermal energy, the specifications are different for the different sub-sectors:

- For geothermal district heating, the measurement of large amounts of water is required (flow rates in the order of 100-500 m³/h in the thermal water circuit are typical). Temperatures can be close to 100 °C or even above. Temperature sensors and flow-meters for industrial applications typically meet the requirements, and the higher cost of this equipment is justified by the high heat output.
- For the geothermal heat pumps in all other applications, measurement is required for both the heat (and cold) supplied to the building system, and for the energy input to the heat pumps (typically electrical power), in order to quantify the renewable energy part (cf. fig. 1). In general, all flow-meters, sensors and calculators available on the market for heating applications are suitable for this task.

A specific problem arises if measurement in the ground circuit of a geothermal heat pump is planned. Flow meters and calculators are typically calibrated to water, while the water-antifreeze-mixture frequently used in the ground circuit has viscosity, density and specific heat differing from that of water. Re-calibration would be necessary.

However, for the quantification of heat supplied according to the rules set up, measuring on the heat supply side (where water is used) and for heat pump energy consumption is sufficient.

It is known that the coefficient of the heating performance of a heat pump decreases with the increase of the temperature difference between the condenser and evaporator. For an ideal heat pump, working on the ideal Carnot cycle, the coefficient of the heating performance is given by:

⁵ Source

$$C_h = \frac{T_c + 273.15}{T_h - T_c} + 1 \quad \Bigg|$$

where:

T_h [°C] = condensation temperature of the working fluid;

T_c [°C] = evaporation temperature of the working fluid.

For a real heat pump, in order to make the heat transfer possible over the entire area of the condenser, the condensation temperature of the working fluid has to be higher than the outlet temperature of heated fluid. For the same reason, the evaporation temperature of the working fluid has to be lower than the outlet temperature of the cooled fluid. Usually the temperature difference is 4°C for both the condenser and the evaporator. Also the coefficient of performance of a real heat pump is reduced roughly by half by the irreversibility of the thermodynamic processes and the mechanic and hydrodynamic losses. An empirical equation for the coefficient of the heating performance of a real heat pump is:

$$C_h = \frac{0.5 \cdot (T_{co} - 4 + 273.15)}{T_{ho} - T_{co} + 8} + 1 \quad \Bigg|$$

Regional Coverage

In the work division, EGEC was in charge to cover Central Europe, and particularly Germany.

Heat measurement is quite common, as e.g. in Germany the measuring of heat delivered is required by law as a basis for billing of heating costs in rented flats, apartments etc.

The relevant technology is available on the market (see some providers below; market leaders are B+R, Brunata, E+H, Ista). There are also companies on the market that provide heat measuring services only (market leader Techem, see below).

- In individual residential buildings, heat measurement is typically not done
- In flats and apartment buildings, heat measurement is done for billing reasons (in Germany); however, there is still a large number of such buildings without heat measuring, in particular in the East
- In district heating systems, heat measuring is a must (for billing reasons); however, even here still are old systems without measuring in operation, in particular in eastern countries

Technology Providers : Providers of measurement systems

Bopp & Reuther Messtechnik GmbH
Am Neuen Rheinhafen 4
D-67346 Speyer
www.burhm.de/

BRUNATA Wärmemesser GmbH & Co. KG
Aidenbachstraße 40
D-81379 München
Tel: (089) 78595-0
www.brunata-muenchen.de/

Endress+Hauser Messtechnik GmbH+Co. KG
Colmarer Straße 6
D-79576 Weil am Rhein
Tel. 0800 3 48 37 87
www.de.endress.com/

Endress and Hauser
Rue Carli 13
B 1140 BRUXELLES
Tel 02/248 06 00
www.endress.com

Ista Deutschland GmbH
Grugaplatz 4
D-45131 Essen
Tel: +49 (0) 201 / 459 – 02
www.ista.de

RESOL GmbH
Heiskampstraße 10
D-45527 Hattingen
Tel.: +49 (0) 2324 - 9648 – 0
www.resol.de

No products, only services:
Techem AG
Hauptstrasse 89
D-65760 Eschborn
Tel. 06196 522-0
www.techem.de

Thermibel
 Pavé du Roelx Z.I.
 B 7110 STREPY-BRACQUEGNIES
 Tel 064/67 15 00
www.thermibel.be

Thermo Electric
 Voorstraat 12
 B 2490 BALEN
www.thermo-electric-direct.com

Accuracy of Heat Measurement Systems

Introduction into accuracy requirements

In the accuracy of Heat Measurement Systems the technical accuracy and non technical mistakes are to be differentiated.

Technical accuracy (measurement system related)

In principle one may recognize three main sources for errors related to reported results. These errors are identified by the origin of it in the overall process to assess reporting data from physical observations.

The three main sources of errors are due to:

1. The instruments and sensors applied for the measurements
2. The measurement of physical parameters itself
3. The numerical analysis of obtained results to assess a desired parameter

The assessment of the technical accuracy of heat measurement systems can be based on the settings of the EU Directive 2004/22/EC on measuring instruments. This Directive defines the following accuracy classes:

Class	$E = E_f + E_t + E_c$ total Error of heat meter	E_{min}
1		~ 2%
2		~3%
3		~4%

Example: class 2 instruments are allowed to show an total error of 3%.

For selected geothermal technology product, we can specify the relative errors along the given criteria:

class	E_f Error of Flow sensor	E_t Error of Tem- perature sensor	E_c Error of calcula- tor	E total error of the heat meter

Non technical accuracy and errors

Errors due to installation, dimensioning of the application or operating conditions are often more problematic than the errors on the hard-/software side of the measurement system.

In a heat pump, the losses appear in different phases and can influence the system :

- Temperature of the cooler fluid, of which the heat is extracted, is several degrees higher than the evaporation temperature;
- Temperature of the heating fluid is several degrees lower than the condensation temperature;
- Heat losses from the connection pipes appear in the plant, even normally heat isolated;
- Friction losses appear in the compressor;
- Characteristics of the cooling fluid differs of the characteristics of ideal one;
- Mechanical and electrical losses in the electro motor appear; and
- Different other losses.

Accuracy of heat measurement in the specific technologies : Geothermal

There are now specific requirements for accuracy in geothermal applications.

The accuracy sufficient for billing purposes in rented flats is deemed adequate for statistical purposes. The main mistakes resulting in inappropriate results can be made by misplacing the sensors and flowmeters.

A specific problem arises with heat pumps with additional electric resistance heater (popular in Scandinavia, but increasingly in Central Europe also); here the energy input to the resistance heater has to be measured, too, as the measurement of heat supply cannot distinguish between heat from geothermal energy and from electric power.

System expenses

The conditions to take into account :

1. Investment for heat meters :
(e.g. investment, installation, others; total costs for a basic version in Euro and costs per kW). Expenses for additional system components (e.g. M-Bus-Interface for remote reading, diagnostic and initial verification; total costs in Euro and costs per kW; investment for the meter to investment of RES-H system)
2. Operating costs :
(e.g. cost for measurement, technical control and revisions and monitoring services, data transmission; total costs in Euro and costs per kW)
3. System life expectation :
(technical life expectation of the system and the life time allowed by the administrative authorities)

The price of one specific system can be very different (calculation tax excluded).

For a system of Resol GmbH composed by:

- 1 flowmeter with impeller (DN 20: 147 € - DN 32 : 315 €)
- 2 resistance temperature detector PT1000 (14 € * 2 = 38 €)
- 1 calculator (136 €)

The complete system is available for 321 – 489 €

For the system of Endress and Hauser composed by:

- 1 electromagnetic flowmeter (DN 50: 1 711 € - DN 200: 3 062 €)
- 2 resistance temperature detector PT100 (2*237 €)
- 1 calculator (726 €)

The complete system is available for 2911 – 4262 €

It is also possible to use a coreolis flowmeter but the price of the flowmeter will be about 8 000 €.

The system proposed by Endress and Hauser is more a system for industrial and scientific application than the system of Resol GmbH which is more a system for personal house application.

Data Processing

After these proposals on measurement system, we have to underline the necessity to define clearly the methodology on how to collect/process these data.

Otherwise the measurements are not available for statistics, support systems etc.

Cost benefit relation

We present now for geothermal applications which parts are typically measured :

- Large geothermal district heating systems are typically measured, throughout Europe.
The measurement is part of the operation strategy, and sometimes also necessary for payments. This can be royalties to state authorities, or sometimes to owners of wells (e.g. in Ferrara, where the wells are owned by AGIP, and the heating system by the municipal company AGEA).
The cost of the systems, even if they are considerable due to the industrial size and standards, is justified by the high heat output.
- Commercial applications with heat pumps are typically measured, in particular for system control and optimisation reasons.
The cost of measuring is justified by the increased efficiency and energy savings due to optimised operation.
- Multi-family houses are measured frequently for billing reasons, so the expenses for measurement equipment are justified.
- Single-family houses typically have no measuring device, only the electric meter for the heat pump power.
The cost of ca. 500-1000 € for an appropriate heat meter is deemed too high, if no financial support is given; there are no extra saving to be achieved by measuring in the residential sector.

Conclusion

For Geothermal Energy, we can conclude in underlining that :

- Large geothermal district heating systems are typically measured, throughout Europe.
As the number of these large systems is not too big, and all of them are known to the authorities, the national associations, etc., it will be relatively easy to compile reliable statistical data for deep geothermal.
A requirement to provide the data to the statistical offices is a prerequisite, however.
- Commercial applications with heat pumps are typically measured, in particular for system control and optimisation reasons.
However, these data are not available to others in most cases, and sometimes are deleted after a short while.
A legal requirement to provide these data to the authorities would be necessary.
- Multi-family houses are measured frequently for billing reasons, so the expenses for measurement equipment are justified.
However, the location and type of the equipment might not be suitable for statistical reasons.
Legal requirements for statistical data would need to include provisions on the type of measurement.
Considering the costs, measuring and reporting of plants above 30 kW heat output seem reasonable (same limit as in VDI 4640 for small geothermal heat pumps plants).
- Single-family residential houses are not measured.
The cost-benefit-ratio is too high for measuring every single house.
It is suggested for plants with less than 30 kW (cf. VDI 4640) to have only random monitoring, and for calculating the heat delivery for the whole number by extrapolation.

References

Related policy documents and Directives

EC DG TREN, Energy & Transport in figures, 2004.
IEA/Eurostat/OECD Energy Statistics Manual, 2004.
White paper. COM (97) 599
Kyoto Protocol (1997)
CEN TC228 prEN14335
MID Metering Instruments Directive
EPB Energy Performance in Buildings Directive, 2002/91
EES Energy End-use and Services Directive
Build-On-RES reports (2004)

Scientific sources and papers

BERA F. (April 2006), personal communication. Professor in the “technologie des industries agro-alimentaire”, Faculté des sciences agronomiques de Gembloux, Belgium
GIECK K. + R. (1997) Formulaire technique. Gieck Verlag, D-82110 Germering

Annex 1: Introduction to Heat Measurement Technologies and Principles (by JRC)

Three technologies are considered under RES-Heat: solar thermal, geo-thermal and biomass. The applications of these technologies are mainly in the building and industrial sector and differ in the size of the plant: small solar thermal collectors for domestic hot tap water, to large geo-thermal district heating plants.

Quantification of the produced heat by a plant is in principle the measurement of a mass-flow (usually water) and a temperature difference. A second way is an empirical method. The produced heat is derived from calculation that has no metrological inputs.

Heat counters, from the smallest domestic appliances to the largest industrial equipment with far more than 10 MWatt ratings, consist of three basic parts:

1. Flow meter (water is used almost exclusively as heat transfer medium)
2. Temperature sensors (usually two parts to measure a temperature difference)
3. Processor (often also called integrator)

An overview of measurement principle could be given. An initial attempt is given below.

Transit Time Meter Basic Theory

Measurements are made by sending bursts of signals through a pipe. The measurement of flow is based on the principle that sound waves travelling in the direction of flow of the fluid require less time than when travelling in the opposite direction. At zero velocity, the transit time or ΔT is zero. If we know the diameter of the pipe, the pipe wall thickness and the pipe wall material the angle of refraction can be calculated automatically and we will know how far apart to space our transducers. The difference in transit times of the ultrasonic signals is an indication for the flow rate of the fluid. Since ultrasonic signals can also penetrate solid materials, the transducers can be mounted onto the outside of the pipe. Fast Digital Signal Processors and signal analysis guarantee reliable measuring results even under difficult conditions where previously ultrasonic flow meters have failed.

Doppler Flow meter Basic Theory

Doppler ultrasonic flow meters operate on the Doppler shift principle, whereby the transmitted frequency is altered linearly by being reflected from particles and bubbles in the fluid. The net result is a frequency shift between transmitter and receiver frequencies that can be directly related to the flow velocity. If the pipe internal diameter is known, the volumetric flow rate can be calculated. Doppler meters require a minimum amount of solid particles or air in the line to achieve measurements.

Thermal Mass Flow Meters

are based on an operational principle that states that the rate of heat absorbed by a flow stream is directly proportional to its mass flow. As molecules of a moving gas/liquid come into contact with a heat source, they absorb heat and thereby cool the source. At increased flow rates, more molecules come into contact with the heat source, absorbing even more heat. The amount of heat dissipated from the heat source in this manner is proportional to the number of molecules of a particular gas/liquid (its mass), the thermal characteristics of the gas/liquid, and its flow characteristics.

Annex 2: Sources of Error (by JRC)

A brief informative note on errors in measurement and analysis.

By definition a source of error is a limitation of a procedure or an instrument that causes an inaccuracy in the quantitative results of an experiment.

In principle one may recognize three main sources for errors related to reported results. These errors are identified by the origin of it in the overall process to assess reporting data from physical observations.

The three main sources of errors are due to:

1. The instruments and sensors applied for the measurements
2. The measurement of physical parameters itself
3. The numerical analysis of obtained results to assess a desired parameter

Concerning item 1

The **precision of a measuring instrument** is determined by the smallest unit to which it can measure. The precision is said to be the same as the smallest fractional or decimal division on the scale of the measuring instrument. Any measurement made with a measuring device is approximate. The sensors used for a specific measurement introduce a specific sensor error.

Sensors and instruments are available on the market that perform the same measurement but that can have a different accuracy or precision. A PT100 temperature sensor can have a higher precision than a thermocouple.

Note that the quality of the instruments and sensors are not related to the measurement itself. A PT100 temperature sensor can be measured in different ways (2-, 3- or 4-wires).

Concerning item 2

Systematic and random errors refer to problems associated with making measurements. All experimental uncertainty is due to either random errors or systematic errors. Random errors are statistical fluctuations (in either direction) in the measured data due to the precision limitations of the measurement device. Random errors usually result from the experimenter's inability to take the same measurement in exactly the same way to get exact the same number. Systematic errors, by contrast, are reproducible inaccuracies that are consistently in the same direction.

If you measure the same object two different times, the two measurements may not be the same. The difference between two measurements is called a **variation** in the measurements. Note that the number of samples taken by the instrument for a single sensor is important as well as is the time of the interval to take the samples that depends a lot on the physical , process to be measured.

Systematic errors are difficult to detect and cannot be analyzed statistically, because all of the data is off in the same direction (either to high or too low). Spotting and correcting for systematic error takes a lot of care. The position of a temperature sensor for example, can be made wrong by the installer, producing data that are not representative for the phenomena that has to be measured.

Concerning item 3

The numerical analysis requires a mathematical model that by definition is an approximation of the physical process and therefore is never perfect. Furthermore the analysis is applied to convert measured data into a parameter that can not be measured directly. A good example is an energy flow. This requires the measurement of a temperature differences in a flow of fluid over a certain period of time with a certain observation interval. The obtained data have to be integrated to assess an energy flow. The errors due to this mathematical process are called **analysis errors**.

Note that some apparatus integrate all aspects of the fore mentioned errors. For example an energy flow meter includes the sensors to measure the physical quantities of temperature and flow and include a software tool to integrate these measured data in order to display directly a value for the energy flow.

Annex 3: Directive 2004/22/EC on measuring instruments

The maximum permissible relative errors applicable to a complete heat meter or an assembled heat meter, expressed in percent of the true value are:

The maximum permissible relative errors applicable to a complete heat meter or an assembled heat meter, expressed in percent of the true value are:

$$E = E_f + E_t + E_c$$

This formula can be inserted in the following table :

class	$E = E_f + E_t + E_c$ total Error of heat meter	E_{\min}	E_{\max}
1		~ 2%	10%
2		~3%	10%
3		~4%	10%

The individual calculations themselves can be highlighted in a separate table:

class	E_f Error of Flow sensor	E_f min $q_p=q$ upper flow level	E_f max $q_p>q$ lower flow level
1	$E_f = (1 + 0,01 q_p/q)$, but not more than 5 %,	~ 1%	5%
2	$E_f = (2 + 0,02 q_p/q)$, but not more than 5 %,	~2%	5%
3	$E_f = (3 + 0,05 q_p/q)$, but not more than 5 %,	~3%	5%

	E_t Error of Temperature sensor	E_t min if ΔT $\min \ll \Delta T$	E_t max if ΔT $\min = \Delta T$
No classes	$E_t = (0,5 + 3 \cdot \Delta T \min / \Delta T)$	~ 0,5 %	3,5%

	E_c Error of calculator	E_c min if ΔT $\min \ll \Delta T$	E_c max if ΔT $\min = \Delta T$
No classes	$E_c = (0,5 + \Delta T \min / \Delta T)$	~ 0,5 %	1,5%

q = the flow rate of the heat conveying liquid;
 q_p = the highest value of q that is permitted permanently for the heat meter to function correctly;
 ΔT = the temperature difference $T_{in} - T_{out}$ with $\Delta T \neq 0$;
 ΔT_{\min} = the lower limit of ΔT for the heat meter to function correctly within the MPEs;